

# DAKA 601C

DAKA Corporation .Industrial Park P.O. Box 90,Pine City, MN 55063 .612/629-6737

INSTALLATION AND OPERATION MANUAL FOR DAKA FURNACE MODEL 601C Price \$3.00

The DAKA Model 601C Supplementary Furnace/Central Furnace was tested on September 25-27, 1980, by PFS Corporation of Madison, Wisconsin, a nationally recognized independent testing agency, for compliance with following standards: UL 727 (June 1979), UL 737 (May 1978) and I.C.B.O. Research Committee Acceptance Criteria for Woodburning Supplementary Furnaces (March 1979). PFS Report No. 256.

## PRINCIPLE OF OPERATION:

The DAKA 601C is a solid-fuel appliance designed for conventional upflow residential central forced-air heating applications. The 601C is equipped with its own living area thermostat, a relay/transformer and a forced-draft blower for convenient and exact control of heat output. The furnace can be used in either of the following ways:

### 1. Supplemental "Add-on" Furnace Application (See Figure 1)

As a supplemental furnace, the DAKA 601C is connected in parallel to a conventional upflow gas, oil or electric furnace, and utilizes the present ductwork to distribute wood-heated air throughout the home with the assistance of the blower on the primary furnace. As long as the heat produced by the DAKA 601C keeps the living area temperature above the setting of the primary furnace room thermostat, the primary furnace will not burn gas or oil, or use any electricity beyond that required to run the main blower. Should the wood fire fail to provide sufficient heat, however, the primary furnace will take over the heating requirements as usual. In this mode, the DAKA 601C is rated for use in conventional homes up to 3000 sq. ft.

### 2. Central Furnace Application (See Figure 2)

The DAKA 601C may also be used as a free-standing furnace, with its own plenums and ductwork. The twin 465-cfm blowers mounted on the DAKA furnace provide enough airflow to satisfy the heating requirements in smaller homes up to 2000 sq. ft. As the woodfire will require periodic attention to maintain its heat output, however, this application is inconvenient and usually requires a second heating system to act as a backup.

## CAUTIONARY NOTES

1. The DAKA 601C is designed for use only in conventional upflow systems, and must deliver wood-heated air to the supply (warm air) plenum of such a system, never to ductwork or cold-air returns. As a woodburner produces heat so long as a fire is burning, the path of such heat must always be upwards through ductwork spaced sufficiently away from combustibles (See Figure 3). This unit is not designed for use as a room heater.
2. The DAKA 601C furnace should be connected to a minimum 6" listed low-heat appliance type ("all-fuel" or "Class A") type chimney serving only the DAKA furnace. Connection to a larger flue, or one serving another appliance such as a water heater or other furnace, in not only in opposition to most building codes, but also causes serious draft problems.

3. A Barometric regulator/damper must be used in the smoke pipe leading to the chimney, and must be set to maintain a .06" draft, as measured by a draft gauge ( such as the one manufactured by Condar Co., Customer Service Dept., Box 6D, Hiram OH. 44234).
4. A solid-disc cast-iron damper must be used in the smoke pipe, to permit shutting off the air supply to the chimney in the event of a chimney fire.
5. Installation in mobile homes is prohibited.
6. The DAKA 601C is designed for wood burning only; burning coal, trash, paper or any other combustible could cause overheating and create a fire hazard, as well as shortening the life expectancy of the combustion chamber and voiding the warranty.
7. To insure that your DAKA furnace is installed in accordance with fire safety and building code regulations, installation by a qualified heating contractor is required. You should also notify your insurance company concerning the installation of any woodburning appliance.
8. The DAKA furnace must be installed with the following clearances to combustible surfaces:

To side wall:	18"	Clearance in front:	48"
To back wall:	36"	Smoke pipe to side wall:	26"
Plenum to ceiling:	2"	Smoke pipe to back wall:	25"

For more information, including instructions on reduced clearance installations, write for publications 89M, 211 and HS-10 from:

National Fire Protection Association  
Publication Sales Department  
470 Atlantic Ave.  
Boston, MA 02210

#### CAUTION!

HOLD FIREDOOR OPEN 1" FOR 5 SECONDS BEFORE FULLY OPENING. INSTALL AND USE ONLY IN ACCORDANCE WITH MANUFACTURER'S INSTALLATION AND OPERATING INSTRUCTIONS. INSPECT AND CLEAN CHIMNEY FREQUENTLY. UNDER CERTAIN CONDITIONS OF USE, CREOSOTE BUILDUP MAY OCCUR RAPIDLY. UNIT TO BE INSTALLED ON NON-COMBUSTIBLE FLOOR.

HOT WHILE IN OPERATION. DO NOT TOUCH, KEEP CHILDREN, CLOTHING AND FURNITURE AWAY. CONTACT MAY CAUSE SKIN BURNS. SEE NAMEPLATE AND INSTRUCTIONS.

KEEP ASH DOOR CLOSED DURING FIRING OF FURNACE TO AVOID DEVELOPING EXCESSIVE TEMPERATURES.

#### DANGER! EXPLOSION HAZARD

NEVER USE GASOLINE, GASOLINE-TYPE LANTERN FUEL, KEROSENE, CHARCOAL LIGHTER FLUID, OR SIMILAR LIQUIDS TO START OR FRESHEN UP A FIRE IN THIS FURNACE. KEEP ALL SUCH LIQUIDS WELL AWAY FROM THE FURNACE WHILE IT IS IN USE.

#### WARNING! FIRE HAZARD

DO NOT EXCEED RATED FLUE DRAFT. DO NOT STORE FLAMMABLE LIQUIDS IN FURNACE ROOM. DO NOT STORE WOOD CLOSER TO FURNACE THAN MARKED CLEARANCES. INSPECT FLUE PIPE AND CHIMNEY FREQUENTLY AND CLEAN OUT SOOT AND CREOSOTE DEPOSITS.

#### CREOSOTE- FORMATION AND NEED FOR REMOVAL

WHEN WOOD IS BURNED SLOWLY, IT PRODUCES TAR AND OTHER ORGANIC VAPORS, WHICH COMBINE WITH EXPELLED MOISTURE TO FORM CREOSOTE. THE CREOSOTE VAPORS CONDENSE IN THE RELATIVELY COOL CHIMNEY FLUE OF A SLOW-BURNING FIRE. AS A RESULT, CREOSOTE RESIDUE ACCUMULATES ON THE FLUE LINING. WHEN IGNITED THIS CREOSOTE MAKES AN EXTREMELY HOT FIRE.

## DISPOSAL OF ASHES

ASHES SHOULD BE PLACED IN A METAL CONTAINER WITH A TIGHT FITTING LID. THE CLOSED CONTAINER OF ASHES SHOULD BE PLACED ON A NONCOMBUSTIBLE FLOOR OR ON THE GROUND, WELL AWAY FROM ALL COMBUSTIBLE MATERIALS, PENDING FINAL DISPOSAL. IF THE ASHES ARE DISPOSED OF BY BURIAL IN SOIL OR OTHERWISE LOCALLY DISPERSED, THEY SHOULD BE RETAINED IN THE CLOSED CONTAINER UNTIL ALL CINDERS HAVE THOROUGHLY COOLED.

---

---

## INSTALLATION INSTRUCTIONS:

### I. UNPACKING

Remove all component parts from firebox for assembly; check piece count against parts list on last page of this manual. (Note: Remove firebrick from carton while still within firebox; do not attempt to lift full carton.)

Parts Shortage: Call or write factory immediately; provide model number and serial number of furnace, found on front mounted data plate, along with a description and quantity of missing parts. Replacements will be shipped at once.

Concealed damage: If any components have been damaged in transit, advise the dealer from whom the furnace was purchased of the nature of the problem, so that a freight claim can be filed.

### II. FURNACE ASSEMBLY

- A. Attach firedoor (Key No. 1 on parts list) to door frame using hinge pin (4) provided. Note that door features a double latch operation to limit initial swing of door to 1" on opening. Continue turning handle clockwise to 3 o'clock position to permit full opening of door. Close door with handle in same position, and rotate counterclockwise to lock.
- B. Insert thermal gasket (6) between ash door (5) and ash pan (7) front, and assemble using two 1/4" bolts and nuts provided.
- C. Insert Smoke Bypass Damper rod (8) through small hole above firedoor, and run rod directly back onto smoke baffle plate inside firebox. Reaching in through smoke collar on back of furnace, screw one large nut onto threaded rod all the way to the end of the thread. Insert threaded rod end into the hole on the upright plate on the Smoke Bypass Damper sliding plate, and screw on second large nut (see Figure 4).
- D. Mount small blower (9) to face of furnace below firedoor, using three hex screws provided.
- E. Remove cast-iron grate (10) and 3" steel grate spacer (11) from firebox. Proceed to install fifteen firebricks (12) along sides and back of firebox, starting at the front, by slipping brick under retaining angle iron and standing them upright on the grate support rails.  
CAUTION! FIREBRICK MUST BE INSTALLED CORRECTLY OR HEAT DAMAGE MAY OCCUR.
- F. Reinstall cast-iron grate in firebox, reinforcing ribs down, resting on side rails. Insert 3" steel grate spacer at rear of grate.

- G. Install two large blowers (13) on back of furnace using hex screws provided. The 6" long blower motor heat shield (14) should be mounted above the two blowers, attached to the furnace by the upper right and left mounting screws on the two blowers (see Figure 5).
- H. Furnace is shipped with air jacket already fitted and installed. If it has worked loose during shipping or unpacking, do the following:
  1. Remove air jacket top (15) by lifting up from front to back only, not side to side.
  2. Ensure that bottom air jacket panel (16) is fully seated between lower bottom support angles.
  3. Ensure that channels welded on air jacket sides (17) engage the lower support channels, and that the side panels are pressed tightly onto furnace around the front and back corners.
  4. Reinstall the air jacket top from back to front, making sure that welded channels along inside edges of top fully engage the top edges of each of the air jacket sides.

### III. FURNACE CONTROL CENTER ASSEMBLY

- A. On DAKA furnace air jacket, locate and remove 3/4" knockout on left or right side whichever will face away from primary furnace.
- B. On 4x4 junction box (18) provided, remove the top center knockout and three opposite bottom knockouts.
- C. Connect fan control (19) to junction box by removing right hand knockout on bottom of control. Attach two knurled nuts to 1" nipple and insert nipple through fan control knockout; install third knurled nut to lock nipple into fan control. Insert other nipple end into top center knockout on junction box, and attach fourth knurled nut to lock nipple onto box.
- D. Insert fan control probe through air jacket knockout hole with junction box below. On side of air jacket, mark four mounting hole locations through back of junction box; use 9/64" drill bit to make holes.
- E. Back junction box away from air jacket, insert 1 1/2" spacer tubes between box and jacket, and insert 2" No. 12 metal screws through spacer tubes to hold junction box 1 1/2" away from air jacket for thermal protection of electronics.
- F. Attach 44" flexible conduit to one bottom hole of junction box, using straight conduit connector; attach 66" flexible conduit to right bottom hole of junction box in same manner.
- G. Attach other end of 44" conduit to small blower junction box on front of furnace using a 90° conduit connector. Attach other end of 66" conduit to one junction box knockout opening of nearer large blower on back of furnace in same manner.
- H. Connect junction boxes on two large blowers on back of furnace using 18" flexible conduit and two 90° conduit connectors.

### IV. WIRING INSTRUCTIONS (See Figure 6).

- A. Attach approved conduit carrying three wire 120V AC 15 amp service to middle knockout hole on bottom of junction box, and attach with conduit connector (not provided). Shut off all power.

- B. Using large wire nut, attach black wire (hot) from 120V service to both the black transformer wire of the R8239C transformer/relay and to one 12" blue wire.
- C. Run blue wire through nipple connecting junction box and fan control, and insert into FAN LINE hole at lower left (Note: Leave tab jumper strip in place on fan control). Insert second 12" blue wire into FAN LOAD hole at upper left of fan control and return through connecting nipple to junction box.
- D. Insert end of 12" yellow wire into LIMIT LOAD hole of fan control at upper right; return other end through junction box nipple, and attach to either black wire going to the relay side of the R8239C transformer/relay (20).
- E. Attach one end of the 56" red wire to other black transformer/relay pigtail with a small wire nut, and run red wire through conduit leading to small blower on face of furnace. Attach to either of two black pigtails on blower with small wire nut.
- F. Connect free blue wire end in junction box to 78" brown wire with a small wire nut. Run through conduit leading to junction box on nearer large blower on back of furnace. Using large wire nut, connect other end of 78" brown wire to either black wire pigtail to blower motor, as well as to second 30" brown wire. Run second brown wire through 18" conduit connecting two blowers, and connect wire end to either black pigtail on second blower, using small wire nut.
- G. Attach one end of 30" white wire to second black pigtail on second large blower using small wire nut. Run other end of white wire back through 18" conduit to other blower, and join it to free black pigtail on first blower and 78" white wire, using large wire nut. Run 78" white wire through 66" conduit back to fan control junction box.
- H. Connect end of 78" white wire to second black pigtail on small front blower, and run through conduit back to fan control junction box.
- I. Connect white wire ends from small front blower, large back blower, transformer/relay and incoming 120V AC service by means of a large wire nut.
- J. Attach relay/transformer plate to face of fan control junction box, making sure all wire connections are fully within box and not pinched by cover. Before fully securing cover, attach green wire (ground) from 120V AC service to any one of the cover securing screws to ground all metal components.
- K. Attach low voltage wire (not included) to "R" and "W" posts on face of transformer. It will be necessary to connect "W" and "G" posts with a low-voltage jump wire, as well. Connect two low-voltage wires to posts on thermostat (21) after it is installed in living area.

-----

V. CONNECTING DAKA FURNACE TO DUCTWORK

- 1. For use as add-on furnace (see figure 1)
  - a. With tin snips or saber saw, cut a 10" circular hole in the air jacket top of the DAKA furnace, and a second 10" circular hole in the side of the supply (warm air) plenum of the primary furnace.

IMPORTANT: Verify beforehand that sufficient clearance is available above air conditioner coils, etc. If sufficient clearance is not available, air conditioner coil may have to be moved to a second plenum with diversion baffles for summer use.

- b. Attach a 90° sheet metal elbow to one end of a straight 10" pipe of a length sufficient to project out over the DAKA furnace; insert this 90° elbow into supply plenum of primary furnace with outlet pointing upward. Slip plenum collar over straight end of 10" pipe and push up tight against supply plenum for a good air seal.

IMPORTANT: The 90° elbow within the supply plenum forms a venturi to extract air from DAKA furnace when primary furnace blower comes on. An absence of this elbow will cause back pressure down the warm air pipe to the DAKA furnace, adversely affecting heat distribution, and possibly damaging the DAKA furnace.

- c. Using 10" starter collar (22) included, attach another straight 10" pipe to top of DAKA air jacket. Join it to pipe leading to primary furnace supply plenum with another 90° elbow. For best seal, apply duct tape to all pipe joints.
- d. Connect cold air return of primary furnace to DAKA furnace blowers by means of a 10" pipe joining the primary cold air return to a sheet metal box fully surrounding the twin blowers on the back of the furnace, leaving a minimum of 2" clearance around the blowers for proper air flow.

NOTE: After attaching warm and cold air supply and return pipes to primary furnace, check entire system to insure that static pressure remains unaffected.

## 2. For use as a central furnace (figure 2)

- a. Install a minimum 16"x16" plenum on air jacket top, cutting top with tin snips or sabre saw as needed, and using starting collar to attach.
- b. Install ductwork with proper clearances to combustibles in accordance with local building codes.
- c. Connect cold air return to a sheet metal box fully surrounding the twin large blowers on the back of the DAKA furnace, leaving a minimum 2" clearance around the blowers for proper air flow.

Note: Filter box No. 258 is available for this purpose through  
your dealer or direct from DAKA.

## VI. CONNECTING DAKA FURNACE TO CHIMNEY

Mount and secure 6" smoke pipe, 24-ga. or heavier, to rear smoke outlet on DAKA furnace. Continue same gauge single-wall pipe to chimney connection, with following safety rules in mind:

1. DAKA furnace must be connected to a listed low-heat appliance type (Class "A" all-fuel) chimney of 6" diameter minimum. Chimney should not be connected to any other appliance.
2. Smoke pipe from DAKA furnace to chimney connection should not be more than 75% of height of chimney above point of connection. Note that each 90° elbow in a smoke pipe is equivalent to six ft. of pipe; never use more than two 90° elbows in any smoke pipe run.
3. Smoke pipe should maintain a minimum 1/4" upslope per foot of length; all smoke pipe joints should be secured by a minimum of three No. 7 sheet metal screws to prevent separation.

4. A solid-disc cast-iron damper should be installed in smoke pipe close to the chimney connection, to cut off oxygen supply in case of a chimney fire.
  5. A barometric regulator should be installed in smoke pipe at least 18" from furnace, to permit adjustment of chimney draft to a maximum of .06" water column draft.
  6. Smoke pipe should maintain a minimum 18" clearance to all combustibles.
  7. Heat reclaimers, fins or the like should not be used on smoke pipe, as they tend to cool flue gases and add to creosote formation on stoves and furnaces of advanced airtight design.
- 

## VII. OPERATING INSTRUCTIONS FOR DAKA FURNACE

### A. Fan Control

The fan control on the side of the DAKA furnace has a rotating thermostat disc. Holding the disc firmly in place, adjust the three tangs for these three settings from left to right as follow: FAN OFF - 90°, FAN ON - 130°, LIMIT - 200°. These fahrenheit settings will cause the twin blowers on the back of the DAKA furnace to turn on when the temperature within the air jacket rises to 130°, and off when the temperature within falls to 90°. The limit setting sets to turn off the small draft blower on the face of the furnace if the air jacket temperature exceeds 200°, as a safety feature, and it keeps the small blower turned off until the temperature drops to about 160°.

While this fan control is designed for fully automatic operation, you can turn twin furnace blowers on manually at any time by pushing white button on fan control in. Pulling button out will turn the twin blowers off, unless the heat within the air jacket is above the "FAN ON" setting of the dial, in which case the blowers will continue to run until the temperature drops.

### B. Living Area Thermostat

#### 1. In a supplementary furnace mode:

- a) The DAKA thermostat is usually installed alongside the primary furnace thermostat, which is set 3-5 degrees lower than the DAKA unit.
- b) When the room temperature falls below the temperature setting on the DAKA thermostat the circuit closes and signals the small blower on the front of the DAKA furnace to turn on, increasing the heat output of the DAKA furnace and thus raising the room temperature to the required level.
- c) If the fire has died down in the DAKA to the point that living area temperature requirements cannot be met, the temperature will then fall to the point where the primary furnace will turn on to hold the temperature at its preset point.

NOTE: The small blower on the DAKA will continue to run whenever the room temperature falls below the setting on the DAKA room thermostat, even when there is no fire left in the DAKA furnace. To turn off, reduce the temperature setting on the DAKA room thermostat below the actual room temperature.

2. In a central furnace mode:

- a) The DAKA thermostat is to be installed on a living area wall at least five feet off the floor. It should never be installed over a warm-air register, nor in a room with a working fireplace.
- b) When the temperature in the room falls below the preset level, the thermostat signals the small blower on the face of the DAKA furnace to turn on, increasing the heat output and raising the temperature in the living area to the required level.

---

VIII. EMERGENCY OPERATION INSTRUCTIONS

A. Operation During a Power Failure

1. Remove furnace filter(s) to prevent fire hazard.
2. Continue firing the fire with smaller loads, more frequently tended.
3. Use extreme care and vigilance during power failure to keep furnace from overheating, which could cause severe warpage or breakage.

CAUTION! Do not expect the DAKA furnace to keep the house as warm during a power failure as when power is on. Do not attempt to increase heat output by opening ash or fire door.

B. What to do in case of a chimney fire:

1. Call the fire department immediately.
2. Close the solid disc damper in the smoke pipe to cut off oxygen to the chimney. Use chimney fire extinguishing flares (available at fireplace and woodstove shops).
3. After chimney fire, do not attempt to use chimney again until a professional inspection is made to determine safety.

---

IX. MAINTENANCE OF YOUR DAKA FURNACE

A. Flue pipe and chimney

1. These must be checked frequently during heating season, and deposits of soot and creosote over 1/8" thick removed using stiff-wire brushes designed for the job. Professional cleaning by a chimney sweep at least once a season is highly recommended.

B. DAKA Furnace Blowers

Lubricate motor bearings after each six months of use; lubrication points are at each end of the motor housing on the side of the motor. Use SAE 20 oil for lubrication. Vacuum away dust and dirt on motor air inlets, and also on blower impellers at least once each season.

CAUTION! Turn off all power to unit before cleaning or lubricating.

C. Fire chamber and ash pan

1. Check ash pan every few days and safely dispose of ashes. Keep ashes from building up on grate and interfering with combustion air flow from below.
  2. At end of heating season, clean out all residual ashes and soot from furnace. The moisture they contain could rust your furnace over the summer months, thereby shortening the life of the unit.
-



X. TROUBLE SHOOTING

A. Problem: Smoke puffback when loading, poor burning, insufficient heat

- Solutions:
1. Insufficient draft--debris or creosote could be blocking flue; inadequate chimney height or design could be causing downdrafts.
  2. Insufficient make-up air--the house could be so well insulated that infiltration air is not getting in to replace air used in combustion; open a window slightly in furnace room or install a vent to the outside in furnace area.

B. Problem: Poor heat throughout house while burning wood

- Solutions:
1. Poor quality wood--burn only wood which has been air dried for at least six months, preferably a year or more.
  2. Check to insure that all cold air return vents are open and not blocked with furniture, etc.
  3. Make sure that all duct joints are airtight, and apply duct tape to seal.
  4. Check flue gas temperature - normal operating range is 300°F - 600°F. Lower temperature would indicate insufficient draft or inadequate combustion air.

To check flue gas temperature, we recommend that a smoke pipe surface thermometer be used. The Chingard thermometer is an excellent device for this purpose, available at many stores, or write:

Condar Company  
Customer Service Dept.  
Box 6D  
Hiram, OH 44234

C. Problem: Paint discoloration (whitish appearance)

Solution: Paint is rated for 900°F surfaces, and overheating of furnace will cause a whitish appearance on outside of combustion chamber surfaces; reduce chimney draft to control overheating.

NOTE: To cover discoloration, obtain a high-combustion flat black spray paint from hardware store or fireplace shop.

---

**FIG. 1 TYPICAL PARALLEL INSTALLATION AS SUPPLEMENTARY FURNACE**

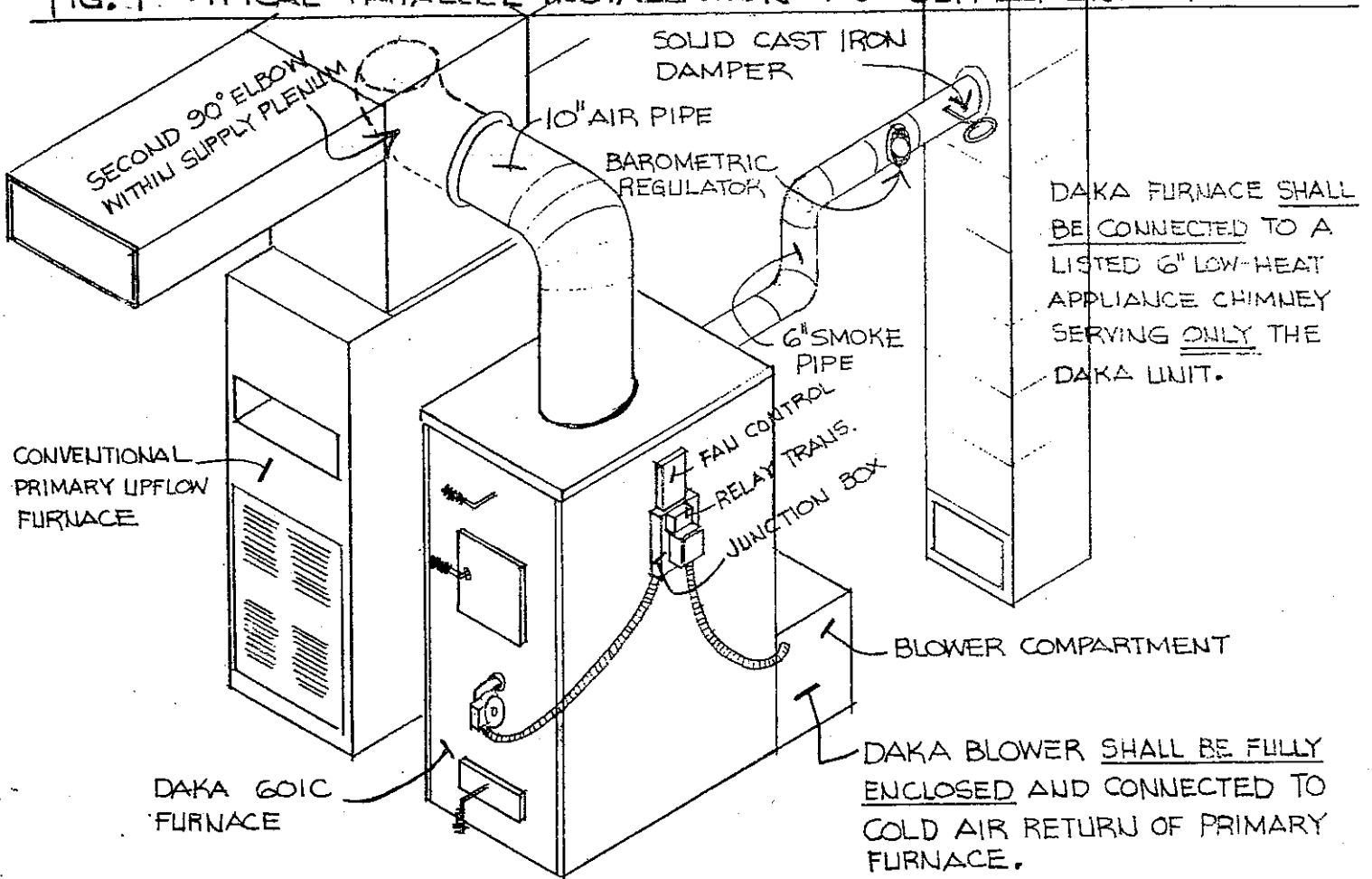

**FIG. 2 TYPICAL INDEPENDENT CENTRAL FURNACE INSTALLATION :**

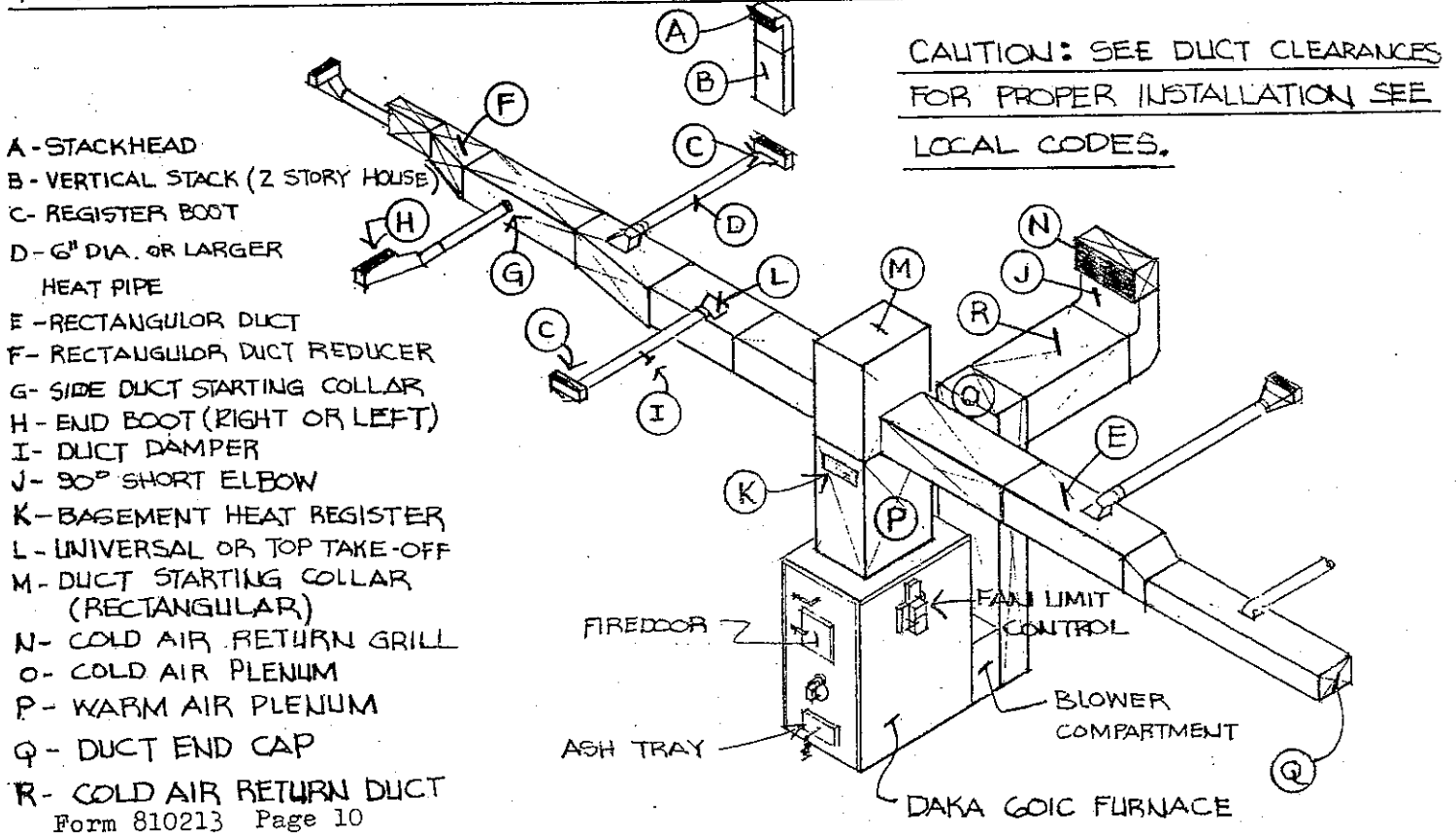
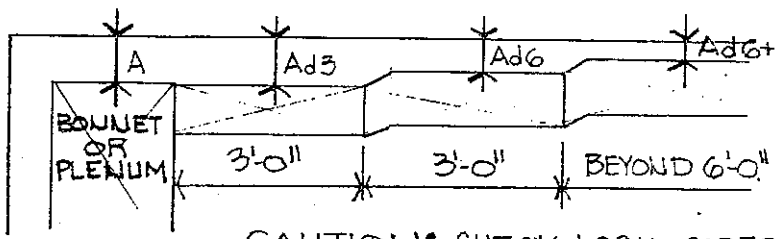

FIGURE 3- DUCT CLEARANCE FOR HORIZONTAL WARM AIR DUCTS.



A = 2"  
 Ad3 = 2"  
 Ad6 = 0"  
 Ad6+ = 0"

CAUTION: CHECK LOCAL CODES BEFORE INSTALLATION!!

FIGURE 4- SMOKE BYPASS DAMPER ROD INSTALLATION.

REAR VIEW OF SMOKE  
 OUTLET ON BACK OF  
 DAKA 601C  
 FURNACE

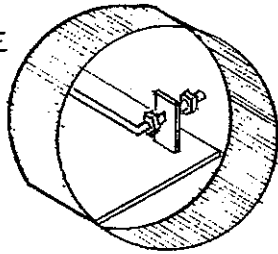
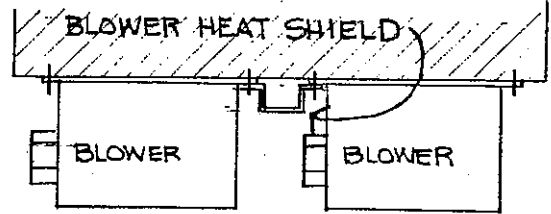
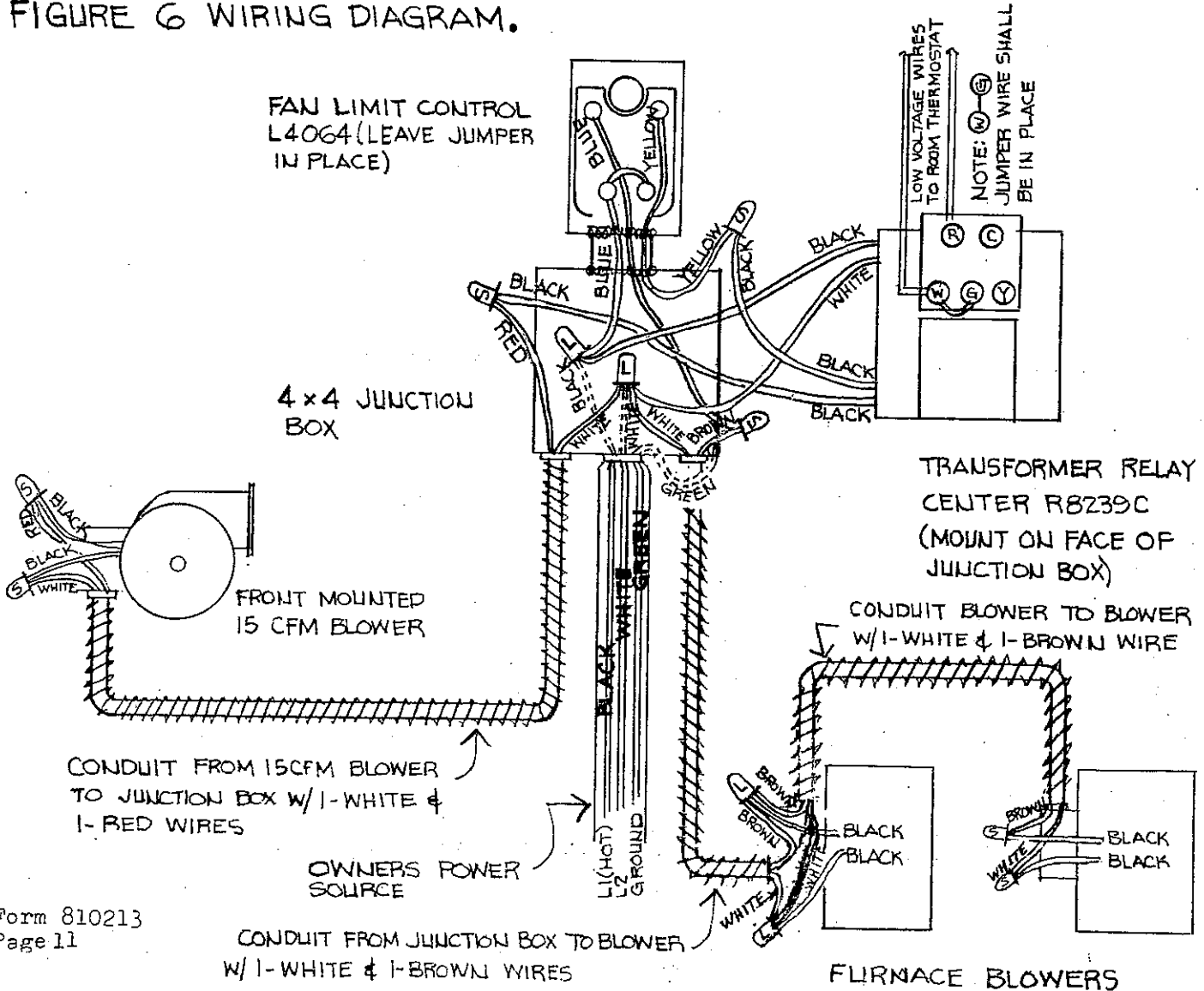

FIGURE 5- BLOWER HEAD SHIELD INSTALLATION.



PLAN VIEW OF FURNACE BLOWERS MOUNTED

FIGURE 6 WIRING DIAGRAM.



# PARTS LIST FOR DAKA 601C FURNACE

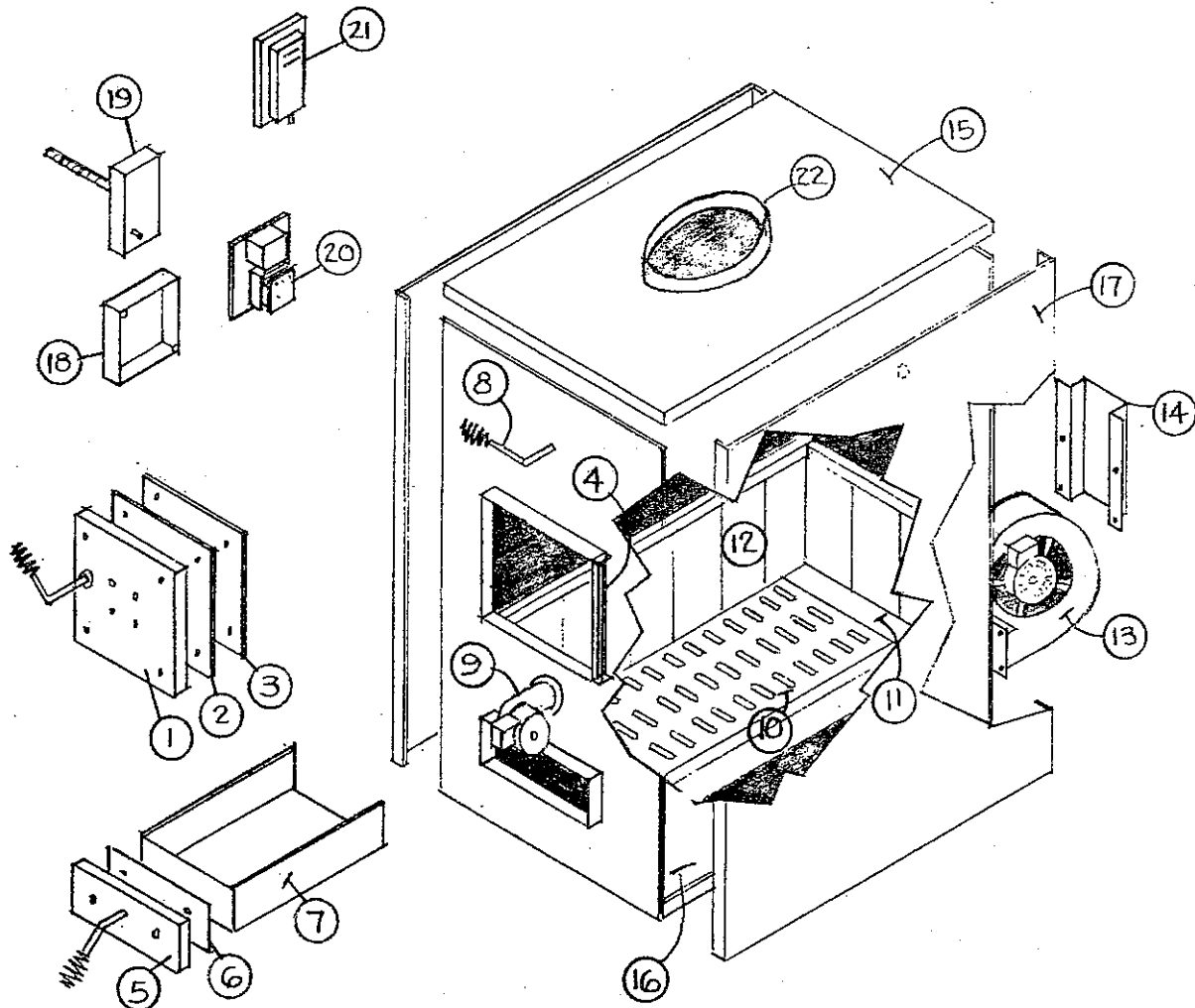

Key No.	Description	Qty.	Key No.	Description	Qty.
1	Firedoor	1	21	T822D Wall Thermostat	1
2	Firedoor Gasket	1	22	10" Starter Collar	1
3	Gasket Plate	1		Hex Bolt - 1/4"	11
4	Hinge Pin	1		Hex nut - 1/4"	11
5	Ash Door	1		Hex metal screw - 2"	4
6	Ash Door Gasket	1		Hex metal screw - 3/4"	11
7	Ash Pan - 27"	1		Flexible Conduit - 66"	1
8	Smoke Bypass Damper Rod	1		Flexible Conduit - 18"	1
9	15-cfm Draft Blower	1		Flexible Conduit - 44"	1
10	Cast Iron Grate - 21"	1		1" Nipple	1
11	Steel Grate Spacer	1		Knurled Nut	4
12	Firebrick	15		Straight Conduit Connector	2 ea.
13	465-cfm Blower	2		90° Conduit Connector	4
14	Blower Motor Heat Shield	1		Wire Nut - Large	4
15	Air Jacket Top Panel	1		Wire Nut - Small	7
16	Air Jacket Bottom Panel	1		Wire - Blue - 12"	2
17	Air Jacket Side Panel	2		Red - 56"	1
18	4"x4" Junction Box	1		Yellow - 12"	1
19	L4064B Fan Control	1		Brown - 30"	1
20	R8239C Transformer/Relay	1		78"	1
	Installation Instr.	1		White - 30"	1
	Warranty Sheet	1		56"	1
	Tube Spacer	4		78"	1
	Smoke Flap Plate	1			