

DAKA SUPPLEMENTARY/CENTRAL SOLID FUEL FURNACE MODEL **3010**

DAKA Corporation . P.O. Box 90 . Pine City, Minnesota 55063

INSTALLATION AND OPERATION INSTRUCTION MANUAL

Note: This model has been tested and listed in accordance with Underwriters Laboratories standard UL 391 for Solid Fuel Central and Supplementary Furnaces by Warnock Hersey International, Inc., a nationally recognized independent testing facility.

PRINCIPLE OF OPERATION:

As a supplementary furnace, this model is connected in parallel to a conventional primary furnace system, utilizing present ductwork to distribute wood-heated air throughout the home with the assistance of the primary furnace blower. As long as the heat produced by the supplementary furnace keeps the living area temperature above the setting on the primary furnace wall thermostat, the primary furnace should not burn any gas, oil, or use any electricity beyond that required to run the primary distribution blower. Should the wood fire fail to provide sufficient heat, however, the primary furnace will begin operating as usual. See Figure 1 for illustration of typical installation.

CAUTIONARY NOTES:

1. This furnace is designed for use only in conventional upflow systems, and must deliver heated air to a supply (warm air) plenum, never to ductwork. The warm air supply from this furnace must never be connected to the cold-air return inlet of a central primary furnace, as a possibility exists of components of the central furnace overheating and causing the central furnace to operate other than as intended.
2. Installation of this unit must be performed by a qualified installer familiar with solid-fuel systems.
3. This furnace must be connected to a minimum 6" listed low-heat appliance type chimney. Connection to a chimney flue serving another appliance is prohibited.
4. A barometric regulator/damper must be used in the chimney connector (smoke pipe leading to chimney flue) and must be set to maintain no more than .06" water column updraft (DAKA barometric regulator #283 with adjustable settings available at extra cost).
5. Installation of this furnace in mobile homes is prohibited.
6. This furnace must be installed with the following clearances to combustible surfaces:

To side wall:	18"	To front wall:	48"
To back wall:	18"		

See Figure 2 for ductwork clearances required.

For more information, including instructions for installations requiring reduced clearances, please write for publications 89M, 211 and HS-10 from:

NATIONAL FIRE PROTECTION ASSOCIATION, INC.
PUBLICATION SALES DEPARTMENT
BATTERYMARCH PARK
QUINCY, MA. 02269

7. Check local building and mechanical codes prior to installation to insure conformance with all requirements; review home insurance policy for coverage.
8. Chimney connector must be of minimum 24-ga. pipe with each section joined with three sheet metal screws, with all fissures sealed with furnace cement. Do not use galvanized pipe as the coating could melt and cause toxic fumes.
9. These furnaces have been designed to operate with a maximum warm air duct pressure of 0.15" water column and a maximum warm air duct temperature of 200°F. When used in a supplementary "add-on" mode, check the nameplate on the primary furnace to determine compatibility.
10. When any supplementary furnace is connected in parallel to an existing primary central furnace, a back-draft damper must be installed in the plenum of the primary furnace below the warm air inlet from the supplementary furnace to prevent the primary furnace from operating in an unintended manner; see Fig. 1 for an illustration of the position of this damper.
11. Installation on a non-combustible floor surface, such as concrete or 3/8" asbestos millboard, is required. Non-combustible surface must extend at least 16" in front of unit, under the chimney connector and at least 2" to each side of connector.

DANGER - RISK OF FIRE OR EXPLOSION - DO NOT BURN GARBAGE, GASOLINE, DRAIN OIL OR OTHER FLAMMABLE LIQUIDS.

WARNING - RISK OF FIRE - DO NOT OPERATE WITH FLUE DRAFT EXCEEDING .06" WATER COLUMN. DO NOT OPERATE WITH FUEL LOADING OR ASH REMOVAL DOORS OPEN. DO NOT STORE FUEL OR OTHER COMBUSTIBLE MATERIAL WITHIN MARKED INSTALLATION CLEARANCES. INSPECT AND CLEAN FLUES AND CHIMNEY REGULARLY.

CAUTION - HOT SURFACES - KEEP CHILDREN AWAY. DO NOT TOUCH DURING OPERATION. MAXIMUM DRAFT MARKED ON NAMEPLATE.

Disposal of Ashes

Ashes should be placed in a metal container with a tight-fitting lid. The closed container of ashes should be placed on a non-combustible floor or on the ground, well away from all combustible materials, pending final disposal. If the ashes are disposed of by burial in the soil or otherwise locally dispersed, they should be retained in the closed container until all cinders have thoroughly cooled.

Creosote - Formation and Need for Removal

When wood is burned slowly, it produces tar and other organic vapors, which combine with expelled moisture to form creosote. The creosote

vapors condense in the relatively cool chimney flue of a slow-burning fire. As a result, creosote residue accumulates on the flue lining. When ignited this creosote makes an extremely hot fire.

The chimney connector and chimney should be inspected at least twice monthly during the heating season to determine if a creosote buildup has occurred. If creosote has accumulated it should be removed to reduce the risk of a chimney fire.

INSTALLATION INSTRUCTIONS:

1. UNPACKING

Remove all component parts from firebox for assembly; check piece count against parts list on last page of this manual. (Note:

Parts Shortage: Call or write factory immediately; provide model number and serial number of furnace, found on top mounted data plate, along with a description and quantity of missing parts.

Concealed Damage: If any components have been damaged in transit, advise the dealer from whom the furnace was purchased of the nature of the problem, so that a freight claim can be filed.

II. FURNACE ASSEMBLY (See Fig. 1 for typical installation illustration).

- A. Remove all items from within firebox; turn Furnace Shell (Key No. 1 in Figure 5) on its back with firedoor opening up.
- B. Insert four Legs (Key 2) in four leg tabs at each corner of furnace shell bottom, with long leg ends in tab slots.
- C. On Furnace Blower (3), remove screws holding air inlet collar in place. Using same screws, mount 5" Starter Collar (4) to face of blower air inlet collar.
- D. Mount furnace blower over air inlet cutout on bottom of furnace, with blower motor to left side, using four #12x $\frac{1}{2}$ " screws provided.

NOTE: Furnace is designed for left side motor and control mounting; should right side mounting be required, duplicate 13/64" mounting holes will have to be drilled in right side of furnace in mirror position, and prepunched holes on left side will have to be sealed with sheet metal screws.

- E. Remove cover from blower electrical junction box and uncoil twin pigtail wires. Remove one knockout plug from end of junction box, and install 90° Conduit Connector.
- F. Attach Snap Disc Fan Control (10) to Fan Control Holder (11) using two No. 10x3/8" screws provided.
- G. On left side of furnace, mount Snap Disc Fan Control assembly (11) over inner two of four 13/64" holes prepunched toward top of furnace, using metal screws provided.
- H. Mount 4x4-in. Junction box extension Ring (12; without ground wire pigtail) over Snap Disc Fan Control, using two metal screws provided in prepunched holes; remove one knockout plug from bottom of extension ring.

- I. Mount second 4x4-in. Junction Box Ring (with ground wire pigtail) on side of furnace approximately 12" below Extension Ring, using metal screws in prepunched mounting holes; remove one knockout plug from top and two from bottom of this junction box.
- J. Install one straight conduit connector in knockout opening on upper J-box extension ring, one on top of lower J-box, and one on bottom. Join two side-mounted J-boxes with 12" flexible conduit provided, and join lower J-box and blower J-box with 18" flexible conduit provided.
- K. Attach firedoor (8) to door frame using hinge pin as provided, Note that door features a double latch operation to limit initial swing of door to 1" on opening. Continue turning handle clockwise beyond 3 o'clock position to permit full opening of door. Close door with handle in same position, and rotate counterclockwise to lock.
- L. Mount Ash Pan Door (5) and Gasket (6) to Ash Pan (7), using nuts and bolts on Ash Pan Door; tighten securely.
- M. After wiring has been completed and unit is stood upright, install Grate (9).

III. WIRING INSTRUCTIONS

WARNING: Disconnect all power before making electrical connections. For power supply connections, use No. 14 AWG or larger wires acceptable for at least 105°C. (Not provided).

- A. Using an approved conduit and connector, bring a 3-wire 120V AC 15-amp minimum electrical service to the lower Junction Box on the side of the DAKA furnace.
- B. Proceed to wire unit in accordance with wiring schematic in Figure 4. Note that the crimp terminals on the high-temperature orange wires attach to each side of the Snap Disc Fan Control.
- C. Check all connections for tightness and electrical safety; coil all wires within junction boxes and install blower junction box cover, and two 4" square J-box Cover Plates (14).

IV. CONNECTING AIR INLET ON DAKA FURNACE BLOWER TO COLD AIR RETURN ON MAIN FURNACE

Note: Not only is this connection required by building codes, but it also serves to maintain level pressures throughout the home, eliminating many causes of poor draft and resulting furnace smoking.

- A. Using tin snips or sabre saw with metal cutting blade, cut a 6" circular hole in cold air return below furnace filter, if possible, and mount second 5" starting collar to return.
- B. Run 5" diameter sheet metal pipe from collar on DAKA blower to collar on main furnace cold air return. Attach pipe to collar with at least three sheet metal screws per connection.

V. CONNECTING HOT-AIR OUTLET ON DAKA FURNACE TO SUPPLY PLENUM ON MAIN FURNACE

Parts needed: 6" diameter 90° elbows, plenum collar, 6" diameter sheet metal pipes (2), screws.

- A. Cut 6" circular hole in supply (hot air) plenum of main furnace on side nearest DAKA furnace, in line with top front 6" outlet.
- B. Attach a 90° elbow to 6" diameter pipe of a length sufficient to reach out over DAKA furnace; insert this 90° elbow into main furnace plenum with outlet pointing upward. Slip plenum collar over pipe and push up tight against plenum for a good seal.
- C. Attach another 6" diam. pipe to top front outlet on DAKA furnace. Join to pipe from main furnace plenum with other 90° elbow. Secure all connections with at least three No. 7 sheet metal screws per joint.

IMPORTANT: The 90° elbow within the supply plenum forms a venturi to extract air from DAKA furnace when primary furnace blower comes on. An absence of this elbow will cause back pressure down the warm air pipe to the DAKA furnace, adversely affecting heat distribution, and possibly damaging the DAKA furnace. If space prohibits installation of 90° elbow as recommended see Fig. 3 for alternate designs.

VI. CONNECTING DAKA FURNACE TO CHIMNEY

Mount and secure 6" non-galvanized smoke pipe, 24-ga. or heavier, to rear smoke outlet on DAKA furnace. Continue same gauge single-wall pipe to chimney connection, with following safety rules in mind:

1. DAKA furnace must be connected to a listed low-heat appliance type (Class "A" all-fuel) chimney of 6" diameter minimum. This flue must not serve any other appliance.
2. A barometric regulator should be installed in smoke pipe at least 18" from furnace, to permit adjustment of chimney draft to a maximum of .06" water column draft. Barometric Regulator No. 283 with adjustable draft settings is available through DAKA dealers or direct from factory for this purpose.
3. Smoke pipe should maintain a minimum 18" clearance to all combustibles, and should never pass unprotected through walls or ceilings; use proper thimbles for those passages.
4. Heat reclaimers, fins or the like should not be used on smoke pipe, as they tend to cool flue gases and add to creosote formation on stoves and furnaces of advanced airtight design.
5. All joints of chimney connector pipe should be secured with a minimum of three No. 7 sheet metal screws, and further sealed with furnace cement to maintain good draft.
6. Smoke pipe should normally be installed with male ends leading from chimney to furnace; should runny creosote be formed in chimney connector, it will then return through pipe to furnace without dripping out of joints.
7. Maintain a minimum of 1/4" per foot of pipe rise to chimney connection; the steeper the rise, the more easily draft will be maintained, generally.

8. Avoid the use of 90° elbows in any chimney connector, as they adversely affect draft. If 90° elbows must be used, do not install more than two in any chimney connector.

VII. OPERATING CONTROLS

A. Snap Disc Fan Control

The snap disc fan control (mounted in the upper J-box extension ring on the side of the DAKA furnace) is designed to turn on the 265-cfm lift blower on the bottom of the DAKA furnace whenever the air temperature within the air jacket exceeds 110°F, and turn it off whenever the air jacket air temperature falls below 90°F. This range is built into the snap disc thermostat and cannot be adjusted.

IMPORTANT: In a supplementary "add-on" installation, the blower on the DAKA furnace is not used as a circulation blower for heating the house, but as a lift blower to get the heat into the supply plenum of the primary furnace. If your primary furnace is not equipped with a fan control in the supply plenum to turn on the primary blower as heat is received from the DAKA furnace, one will have to be installed, wiring it in parallel with the primary blower fan control at the heat exchanger level. See Fig. 1 for necessary position of this fan control.

B. Automatic Damper Control

The automatic damper control on the firedoor consists of a bimetallic coil spring and draft door assembly. As the heat from the firebox reaches the spring, it automatically contracts and lowers the draft door to reduce the combustion air; as the fire dies down, the coil spring automatically expands and lifts the draft door, adding more combustion air and freshening the fire. To start the fire, we recommend the knob control be set on "HIGH"; for extended burning, a setting between "OFF" and "HIGH" will have to be found through experimentation for your particular installation, (NOTE: If draft control shaft will not hold a setting, tighten only the shaft nut closest to the coil spring by turning counterclockwise with a 7/16" open-end or adjustable wrench).

IMPORTANT: Normal operation will produce flue gas temperatures in the 300°-600°F range. If higher or lower operating temperatures are normally obtained, increase or decrease the barometric draft control setting and/or the automatic damper control setting to bring temperatures to within range. Too cool a flue gas temperature can result in heavy creosote formation, while too hot a temperature increases danger of chimney fire.

VIII. EMERGENCY OPERATION INSTRUCTIONS

A. Operation During Power Failure

1. Remove furnace filter(s) to prevent fire hazard.
2. Continue firing the fire with smaller loads, more frequently tended.

3. Use extreme care and vigilance during power failure to keep furnace from overheating, which could cause severe warpage or breakage.

CAUTION! Do not expect the DAKA furnace to keep the house as warm during a power failure as when power is on. Do not attempt to increase heat output by opening ash or fire door.

B. In Case of a Chimney Fire:

1. Call the fire department immediately.
2. Use Chimney fire extinguishing flares if you have them. (Available at fireplace and woodstove shops).
3. After chimney fire, do not attempt to use chimney again until a professional inspection is made to determine safety.

IX. MAINTENANCE OF YOUR DAKA FURNACE

A. Flue pipe and chimney

These must be checked frequently during heating season, and deposits of soot and creosote over 1/8" thick removed using stiff-wire brushes designed for the job. Professional cleaning by a chimney sweep at least once a season is highly recommended.

B. DAKA Furnace Blowers

Lubricate motor bearings after each six months of use; lubrication points are at each end of the motor housing on the side of the motor. Use SAE 20 oil for lubrication. Vacuum away dust and dirt on motor air inlets, and also on blower impellers at least once each season.

CAUTION! Turn off all power to unit before cleaning or lubrication.

C. Fire chamber and ash pan

1. Check ash pan every few days and safely dispose of ashes. Keep ashes from building up on grate and interfering with combustion air flow from below.
2. At end of heating season, clean out all residual ashes and soot from furnace. The moisture they contain could rust your furnace over the summer months, thereby shortening the life of the unit.

X. TROUBLE SHOOTING

A. Problem: Smoke puffback when loading, poor burning, insufficient heat

Solutions: 1. Insufficient draft--debris or creosote could be blocking flue; inadequate chimney height or design could be causing downdrafts; check chimney connector for air leaks and seal with furnace cement; adjust barometric regulator to higher setting.

2. Insufficient make-up air-- the house could be so well insulated that infiltration air is not getting in to replace air used in combustion; open a window slightly in furnace room or install a vent to the outside in furnace area.

B. Problem: Poor heat throughout house while burning wood

- Solutions:
1. Poor quality wood--burn only wood which has been air dried for at least six months, preferably a year or more. Use hardwoods such as hickory, oak, maple, etc. for highest heat value per load.
 2. Check to insure that all cold air return vents are open and not blocked with furniture, etc.
 3. Make sure that all duct joints are airtight, and apply duct tape to seal.
 4. Check flue gas temperature - normal operating range is 300^oF - 600^oF. Lower temperature would indicate insufficient draft or inadequate combustion air.

To check flue gas temperature, we recommend that a smoke pipe surface thermometer be used. The Chimgard thermometer is an excellent device for this purpose, available at many stores.

5. Insure that primary furnace blower is turning on to distribute heat effectively. Lower "FAN ON" setting on primary furnace fan control to start circulation earlier.

C. Problem: Paint discoloration (whitish appearance)

Solution: Paint is rated for 900^oF surfaces, and overheating of furnace will cause a whitish appearance on outside of combustion chamber surfaces; reduce chimney draft to control overheating.

NOTE: To cover discoloration, obtain a high combustion flat black spray paint from hardware store or fireplace shop.

If problems persist, or help is needed in installation or operating of furnace, contact:

Customer Service Department
DAKA Corporation
P.O. Box 90
Pine City, MN 55063
Telephone: 612/629-6737

FIG. 1 TYPICAL PARALLEL SUPPLEMENTARY FURNACE INSTALLATION

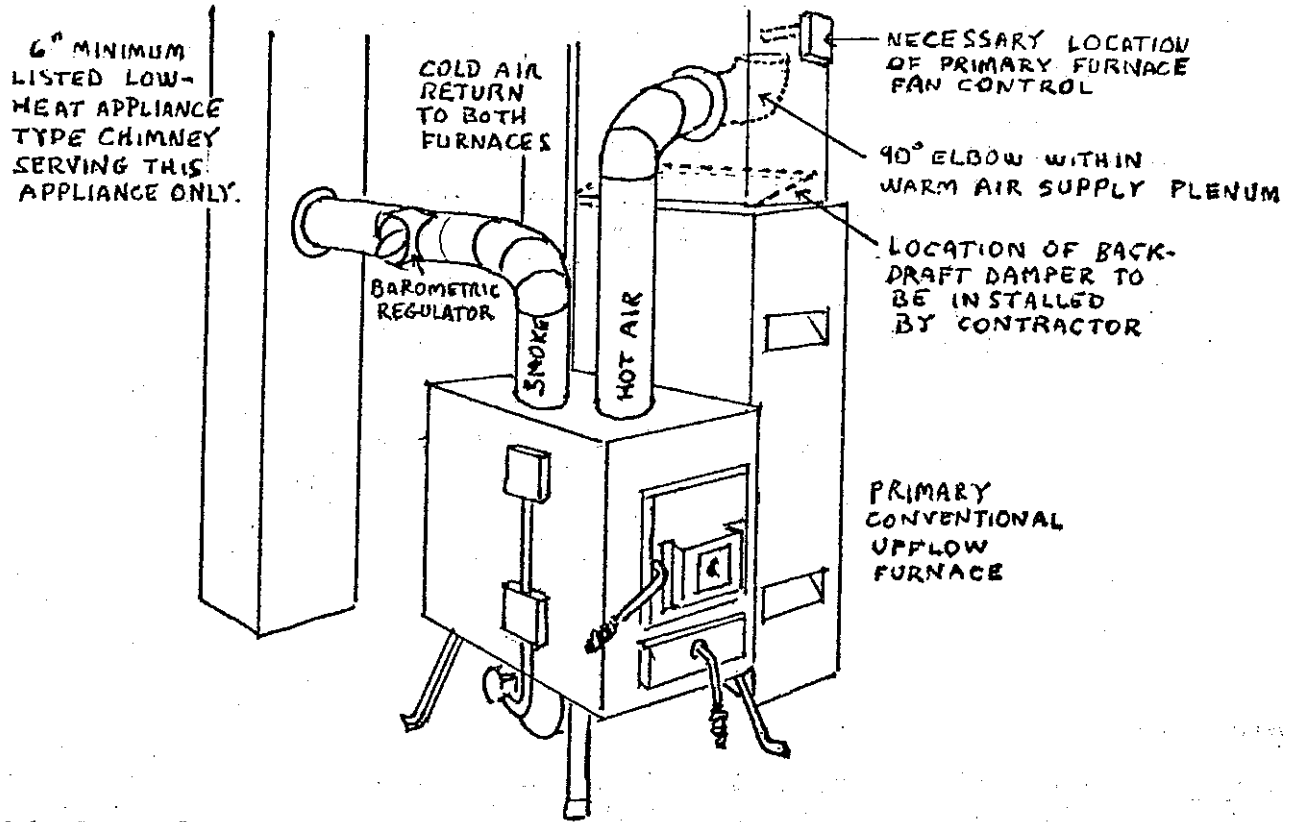

FIG. 2- CLEARANCES FROM HORIZONTAL WARM AIR DUCTS

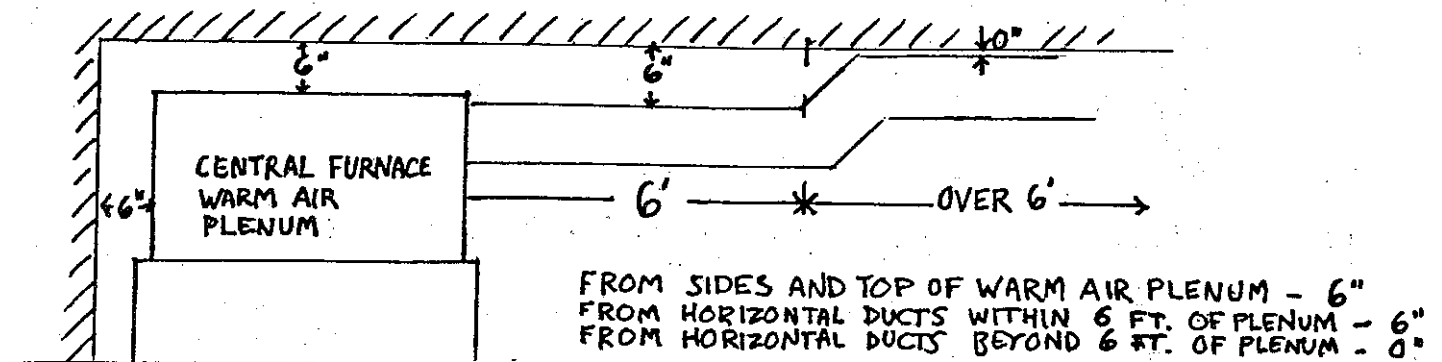

FIG. 3 - ALTERNATIVE WARM AIR PIPE INSERT DESIGNS

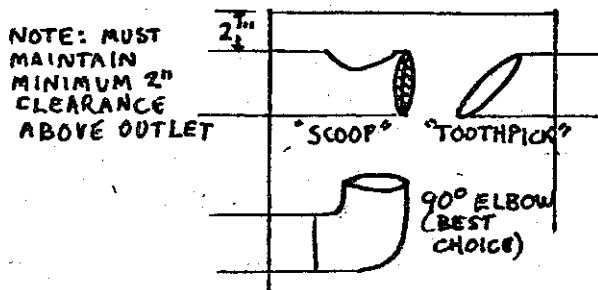

FIG. 4 WIRING DIAGRAM

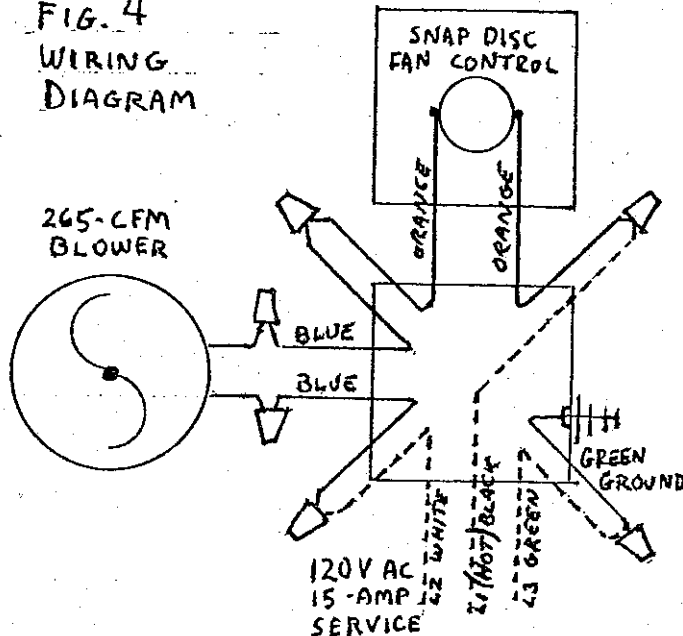
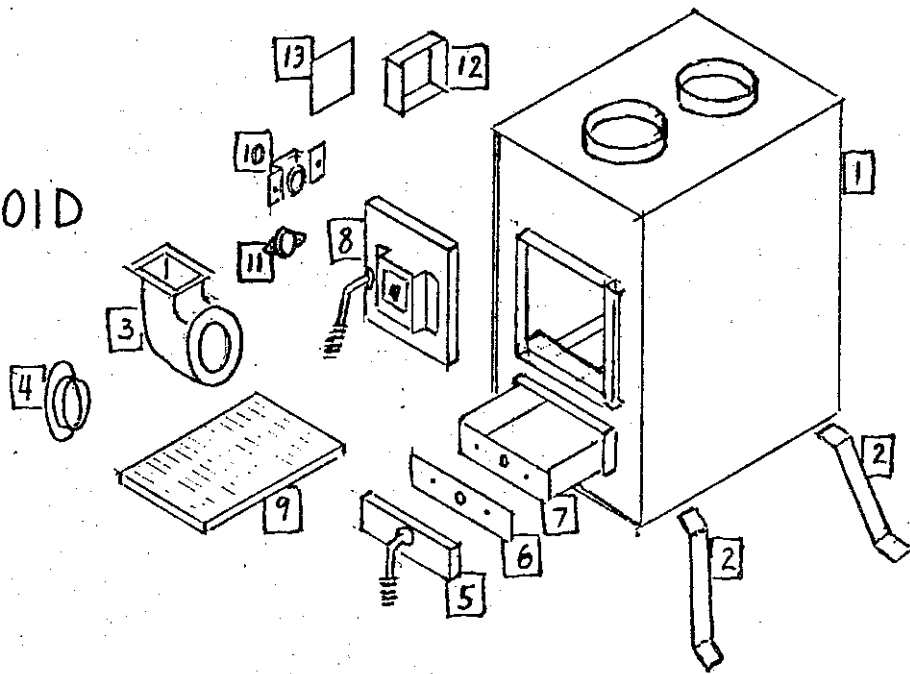

FIG. 5
PARTS
DIAGRAM
MODEL 301D



PARTS LIST

Key No.	Part No.	Description	Qty
1	590000	Furnace Shell - A Type	1
2	660003	Leg	4
3	610002	Blower - 265 cfm	1
4	811157	Starter Collar - 5"	1
5	811135	Ash Door	1
6	610202	Gasket - Ash Door	1
7	811138	Ash Pan - 21"	1
8	811190	Firedoor w/gasket - Auto. Damper	1
9	810439	Grate - Cast Iron - 18"	1
10	640004	Snap Disc Fan Control	1
11	640006	" " " " Holder	1
12	630601	Junction Box Extension Ring - 4x4"	2
13	630602	J-Box Cover Plate	2
-	630402	Flexible Conduit - 12"	1
-	630403	" " - 18"	1
-	630802	Wire Nut	6
-	660005	Hinge Pin	1
-	660208	Sheet Metal Screw - No. 12- $\frac{1}{2}$ "	10
-	660217	" " " - No. 10- $\frac{3}{8}$ "	2
-	670001	Wire Set - 2 blue, 2 orange	1
-	670201	Conduit Connector - Straight	3
-	670202	" " - 90°	1

LIMITED WARRANTY

DAKA Corporation warrants the combustion chambers of its supplementary furnaces to be free of defects in material or workmanship for five years from date of sale; all other components, including electronics, gaskets and grates are covered in the same manner for a period of one year.

DAKA will repair or replace defective components, at our option, at no charge for parts and labor, and will pay freight charge for one-way shipment for warranty claims during first year. In second and subsequent years, only parts and labor will be provided at no charge.

Warranty void if unit is used in other than residential service connected to conventional basement-type upflow central heating system, if non-approved fuels are used in firing of units, or if unit is damaged due to accident, improper installation or negligence.

For service under this warranty, contact selling dealer or DAKA Corporation, Customer Service Dept., Industrial Park, P.O. Box 90, Pine City MN 55063; telephone 612/629-6737.

This warranty gives you specific legal rights, and you may also have other rights which vary from state to state.

