

APPLICATION

The L4064B and W Combination Fan and Limit Controllers are suitable for all types of forced air heating systems.

They provide high limit control of the burner and control of the fan motor according to plenum temperature. A manual fan switch can be used to override the fan set point and keep the fan running continuously.

The L4064W fan switch contains a heater-wrapped bimetal to actuate the fan switch independent of the temperature at the helical bimetal sensing element. Thus, the fan comes on either when the helical sensing element reaches the fan-on setting or when the heater-wrapped bimetal in the fan switch turns the fan on (approximately 20 to 90 seconds after a call for heat).

Limit contacts are suitable for line voltage, low voltage or millivoltage circuits.

INSTALLATION WHEN INSTALLING THIS PRODUCT...

1. Read these instructions carefully. Failure to follow them could damage the product or cause a hazardous condition.
2. Check the ratings given in the instructions and on the product to make sure the product is suitable for your application.
3. Installer must be a trained, experienced service technician.
4. After installation is complete, check out product operation as provided in these instructions.

WARNING

Failure to remove brass jumper, if limit switch is in low voltage circuit, can cause electrical shock hazard or damage low voltage controls.

CAUTION

1. Disconnect power supply before connecting wiring to prevent electrical shock or equipment damage.
2. When connecting cable or conduit to control, avoid straining the control case.

Follow furnace or burner manufacturer's instructions, if available. The L4064B has a maximum switch temperature of 190 F [88 C], maximum element temperature of 350 F [177 C]. The L4064W has a maximum switch temperature of 115 F [46 C], maximum element temperature of 350 F [177 C]. Do not exceed these temperatures or the following electrical ratings (amperes):

	120 Vac		240 Vac	
	FAN	LIMIT	FAN	LIMIT
Full Load	14	8	7	4
Locked Rotor	84	48	42	24

Pilot Duty: 2 A at 24 Vac; 0.25 A at 0.25 to 12 Vdc. Maximum Combined Connected Load: 2000 VA. 75 C [167 F] (min.) field wiring required. Wiring must conform to NEC Class 1 requirements.

LOCATION

If this is a replacement installation, locate the L4064 in the same location as the control being replaced. Sensing tube length should be same as old control. If this is a new installation, the element should be installed only by a trained, experienced service technician according to the furnace manufacturer's instructions. The element must not touch any internal part of the furnace.

NOTE: If plenum surface temperature exceeds 190 F [88 C], heat insulating material or mounting bracket must be used.

MOUNTING

The devices may be mounted either on the plenum surface or with a bracket (rigid or swivel).

SURFACE MOUNTING

Hole in plenum should be just large enough to accommodate the 3/4 in. [19.1 mm] diameter element tube, Fig. 1. For adequate clearance, a 13/16 in. [20.6 mm] diameter hole is recommended.

1. Remove cover by squeezing sides and pulling off. Insert element in plenum and mark location of mounting holes. Make sure the case is snug against the plenum before marking the mounting screws.

2. Punch or drill holes for mounting screws.

3. Place insulation between plenum and case if necessary.

4. Fasten controller securely with mounting screws.

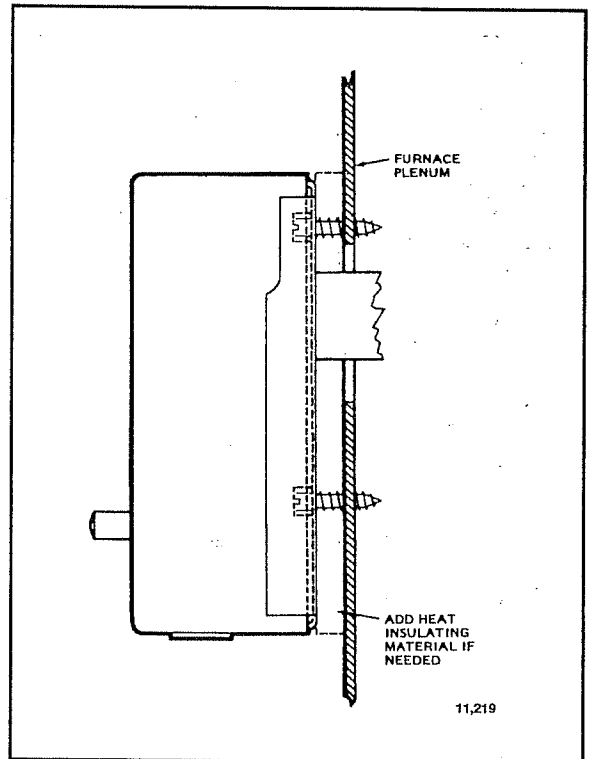

Fig. 1—Surface mounting requires a hole 13/16 in. [20.6 mm] diameter element insertion.

SWIVEL MOUNTING

L4064B,W may also be swivel-mounted. The swivel bracket requires a 1-9/16 in. [39.7 mm] hole in the plenum (Fig. 2).

1. Use bracket as a template to mark the location of mounting holes in plenum. Drill or punch holes for mounting screws.
2. Fasten the bracket in place with furnished screws. Start the screws but do not tighten.
3. Insert element tube through bracket, straighten controller, and fasten. Tighten the mounting screws securely. It may be necessary to rotate the bracket to tighten all screws securely.

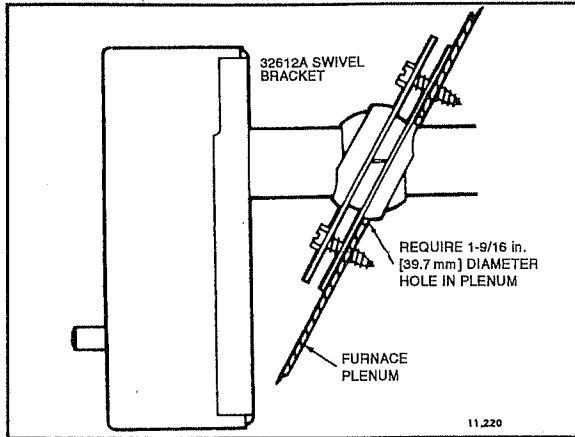

Fig. 2—Swivel mounting requires a 1-9/16 in. [39.7 mm] diameter mounting hole for element insertion.

RIGID BRACKET MOUNTING



When mounting control on bracket, setscrew must strike tube frame, not sensing element. If setscrew strikes the sensing element, the safety limit function can fail and cause fire hazard.

L4064B,W may be mounted using a rigid bracket. The rigid bracket requires a hole 13/16 in. [20.6 mm] diameter for element insertion (Fig. 3).

1. Use bracket as a template to mark the location of mounting holes in plenum. Drill or punch holes for mounting screws.
2. Fasten bracket in place with furnished screws. Tighten the screws securely.

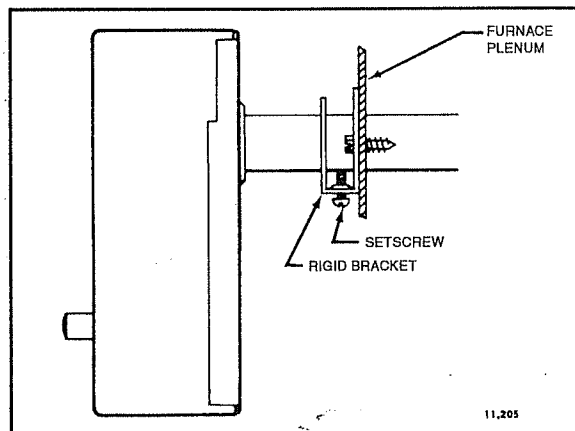

Fig. 3- Rigid bracket mounting requires a hole 13/16 in. [20.6 mm] diameter for element insertion.

3. Insert element tube through bracket, straighten controller and fasten by tightening setscrew. Be sure screw strikes tube frame and does not strike sensing element.

WIRING

Disconnect power supply before beginning installation to prevent electrical shock or equipment damage.

All wiring must comply with local electrical codes and ordinances or in the absence of local codes with the National Electrical Code ANSI C1-1981-NFPA 70. Follow burner or furnace manufacturer's instructions if available; otherwise, see Figs. 6 and 7 and proceed as follows.

IMPORTANT

The brass jumper is the breakaway type. It must be removed when the limit is used in the low voltage circuit. To remove jumper, break with a needlenose pliers and remove completely. Once removed, it is not replaceable. See Fig. 5 for location.

The slotted knockouts on the bottom of the case and the strain relief bushing are provided to simplify the installation procedure and to protect the wires.

1. To remove the slotted knockout(s) use a needlenose pliers as shown in Fig. 4 and pull straight down.

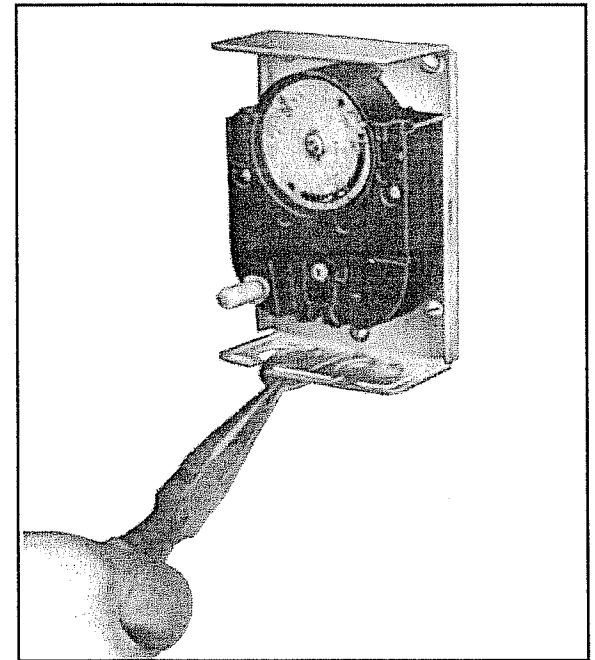

Fig. 4—Removing slotted knockouts.

2. If cable is used, we recommend using a strain relief bushing in the knockout. Bushing is available from your local electrical supply. The open side of the bushing should face the open side of the knockout.

3. Refer to the following section for type of wiring connections (standard wire push-in terminals or female receptacle).

4. If strain relief bushing is used, close the movable gate when all wires have been connected to the terminals.

WIRING CONNECTIONS

When connecting cable or conduit to this controller, use care to avoid strain on the control case. Connections can be made to standard wire push-in terminals or female receptacles for 1/4 in. [6.4 mm] male flag connectors on both the fan and limit switches (Fig. 5).

FOR STANDARD WIRE PUSH-IN TERMINALS

Connect wires to the terminals as follows:

1. Use Nos. 14, 16, or 18 solid wire or Nos. 14 or 16 stranded wire, depending on electrical requirement.
2. Strip insulation from wires the distance shown by the strip gauge on the controller. If wire insulation is 4/64 in. [2 mm] thick, strip additional 1/4 in. [6 mm] to ensure wire seats securely in push-in connectors.
3. Solid wire may be inserted directly into the terminal holes. If stranded wire is used, insert a small screwdriver into the slot next to the terminal. Push screwdriver in and hold while inserting wire into terminal. Remove screwdriver. If stranded wire is solder-dipped, it can be pushed directly into terminal holes.

FOR FEMALE RECEPTACLE —

It is recommended that the female receptacles be used for wiring accessory equipment; i.e., electronic air cleaner, humidifier, etc.

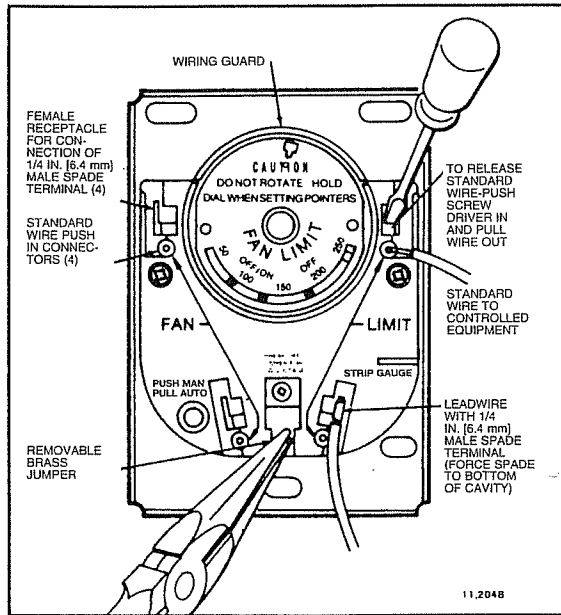

Fig. 5—Location of wiring connections.

- Connect wires to the receptacles as follows:
1. Use Nos. 14 to 18 size wire, depending on electrical requirement.
 2. Attach 1/4 in. [6.4 mm] male flag connector to each wire. Two male connectors with leadwires are supplied.
 3. Push male flag connector directly into the female receptacle. Make sure that the flag is forced to the bottom of cavity and wire is in the channel (Fig. 5).

IMPORTANT
Make certain all wires are clear of rotating scaleplate.

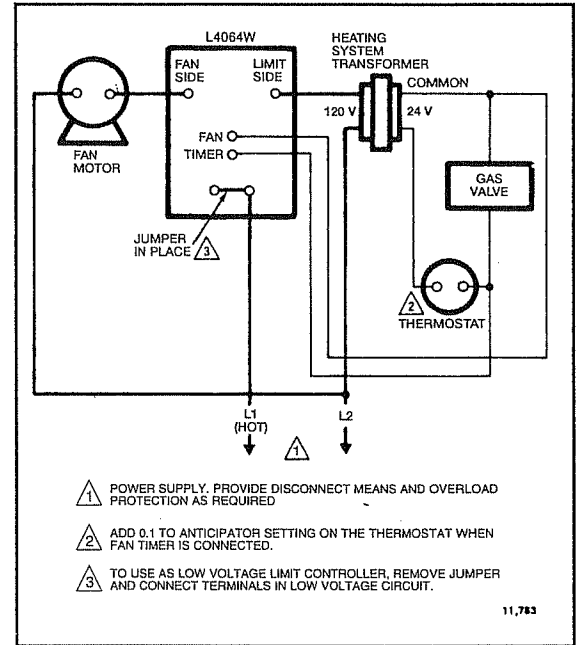

Fig. 6—L4064 3-wire line voltage hookup.

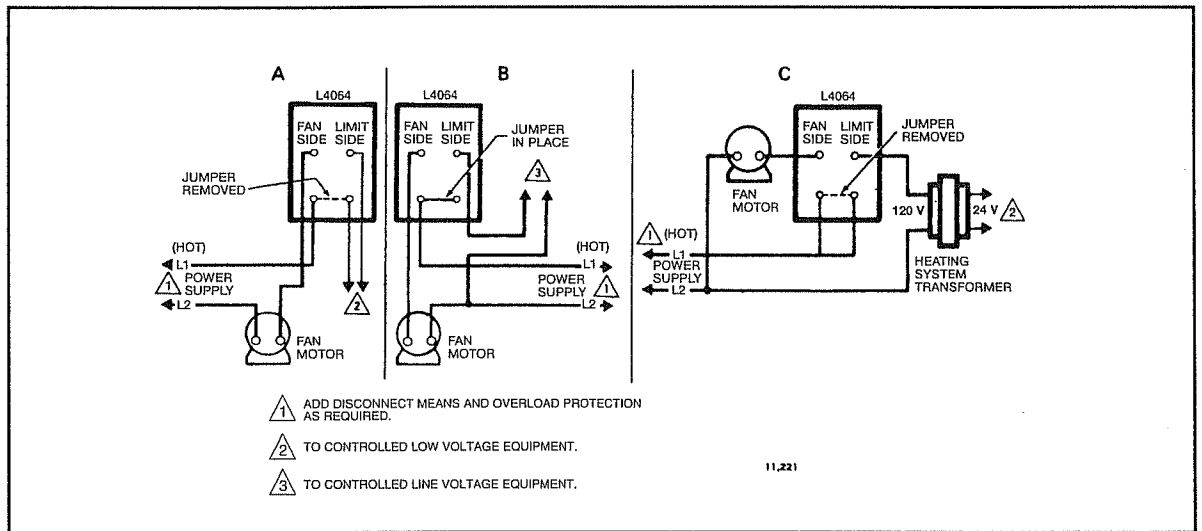

Fig. 7—L4064B A: Limit in low voltage circuit.
B: Limit in line voltage circuit.
C: Limit in line voltage circuit without jumper.

SETTINGS AND ADJUSTMENTS

CAUTION

When adjusting the fan and limit set point levers (Fig. 8), hold the scaleplate dial to keep it from turning and straining the sensing element.

Move each indicator lever to the control point recommended by the burner or furnace manufacturer. Use gentle finger pressure.

FAN SETTING ADJUSTMENT

1. Move the FAN OFF lever to the temperature at which the fan is to stop to prevent circulation of cool air.

2. Move the FAN ON lever as follows: FAN ON range is from 20 F [11.1 C] above the FAN OFF setting to 30 F [16.7 C] below the LIMIT OFF setting.

3. L4064W—Move the FAN ON lever as needed for setting the FAN OFF indicator and LIMIT indicator. The FAN ON indicator is nonfunctional on the L4064W; a special heater-wrapped bimetal acts to turn on the fan 20 to 90 seconds* after a call for heat from the thermostat. On-time will vary, depending on the voltage applied to the heater and on the temperature surrounding the fan switch.

**The fan-on timing can vary depending on applied voltage and switch ambient.*

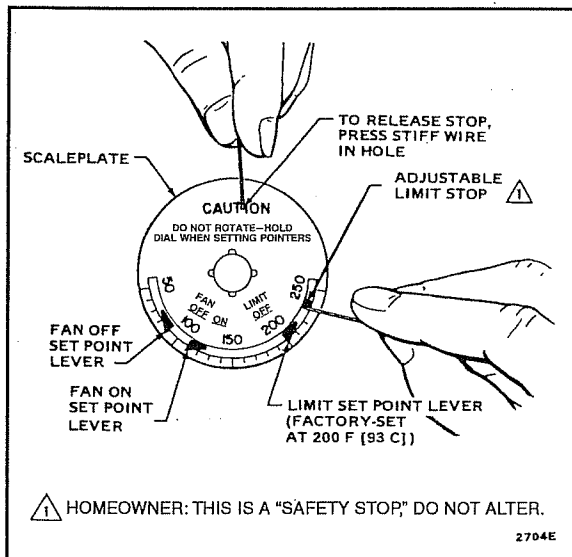

Fig. 8—Changing the high limit stop.

MANUAL FAN SWITCH

For constant fan operation, push the FAN switch button in. For fan to cycle automatically, pull button out.

LIMIT STOP ADJUSTMENT

These controllers have a limit stop which prevents the limit indicator lever from being adjusted beyond the equipment manufacturer's specifications.

1. Push a stiff wire through hole in scaleplate to depress the stop disc not more than 1/16 in. [1.6 mm] to release stop lock (Fig. 8). Stop disc is on back of scaleplate.

2. While depressing the stop disc, insert another stiff wire next to limit stop (Fig. 8) and use this wire to move stop to desired setting. *If the L4064 is replacement control, high limit stop setting should be the same as that of the control being replaced.* (Move stop clockwise ↻ to lower the setting, counterclockwise ↺ to raise it.) Then remove both wires.

Set the LIMIT OFF lever to the temperature at which the high limit switch is to open to stop the burner. If the high limit stop has been properly set, the LIMIT OFF lever should be as high as the stop permits.

OPERATION

As the plenum temperature rises, the bimetal sensing element of the control warps and mechanically makes the fan contacts (at the FAN ON temperature setting). During normal operation, the call for heat ends before the LIMIT setting is reached, and the fan contacts break as the plenum temperature falls and the FAN OFF setting is reached.

If the call for heat continues until the temperature in the plenum rises to the LIMIT setting, the bimetal element will mechanically break the limit contacts and de-energize the heating control circuit.

CHECKOUT

When installation is complete, disconnect the fan motor circuit at the L4064. Turn on power and set thermostat to call for heat. Burner should come on and limit controller should shut burner off when plenum temperature reaches the limit set point. Turn off power, reconnect the fan switch, turn on power and again set thermostat to call for heat.

On L4064B fan should start when plenum temperature has reached fan-on setting. On L4064W fan should start 20 to 90 seconds after a call for heat. Fan should shut off on both L4064 models when call for heat ends and plenum has cooled to fan-off setting. The L4064W shuts off the fan when the sensing element and the bimetal heater have cooled to the fan-off setting. This is usually 2 to 4 minutes after the call for heat ends.

International Sales Offices in all principal cities of the world. Manufacturing in Australia, Canada, Finland, Germany, Japan, Mexico, Netherlands, Spain, Taiwan, United Kingdom, U.S.A.

Home and Building Control

Honeywell Limited
155 Gordon Baker Road
North York, Ontario
M2H 3N7

Home and Building Control

Honeywell Inc.
1985 Douglas Drive North
Golden Valley, Minnesota
55422

Honeywell

Helping You Control Your World

Printed in Canada